

Pentair Sand filter fibreglass reinforced polyester 1 1/2" female thread 2,5bar blue type Triton® F-19S8-NEO-CP (7021210)



TECHNICAL SPECIFICATIONS

Colour	blue
Material	fibreglass reinforced polyester
Connection	female thread
Pressure	2,5 bar
Max. temp.	50 °C
Type	Triton® F-19S8-NEO-CP
Capacity	8,5 m ³ /h
Gravel	25 kg
Size	1 1/2"
Diameter	480 mm
Weight	13.4 kg
Sand	50 kg
Filter area	0.17 m ²
Max flow rate	8.5 m ³ /h
Max. pool vol.	42.5 m ³

DIMENSIONS

B 19 " inch

A 785 mm

B 480 mm

C 524 mm

D 463 mm

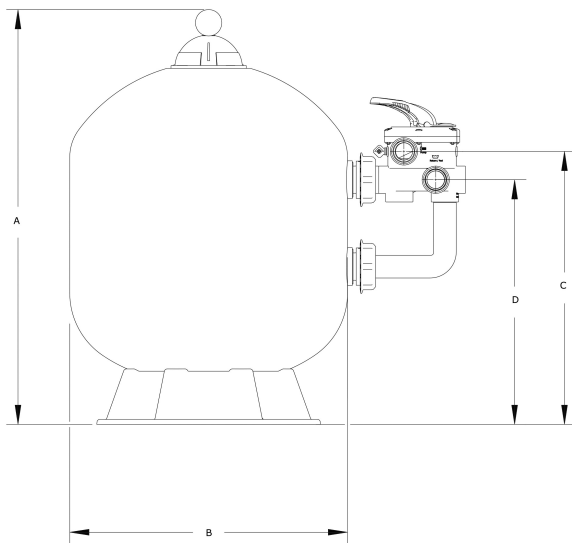

PRODUCT INFORMATION

One-piece, fibreglass-reinforced tank with UV-resistant coating.

With side-mount 6-way valve.

Switch off the pump before each lever action.

Warranty period: Tank 10 years

Last modified date: 06/11/2025

Bosta UK Ltd.
Reflection House
Olding Road
Bury St. Edmunds
Suffolk
IP33 3TA
T +44 (0) 1284 716580
E enquiries@bosta.co.uk
<http://www.bosta.com>